

Double-sided illuminated CLV Showcase

L6-200

Anchoring below ground level

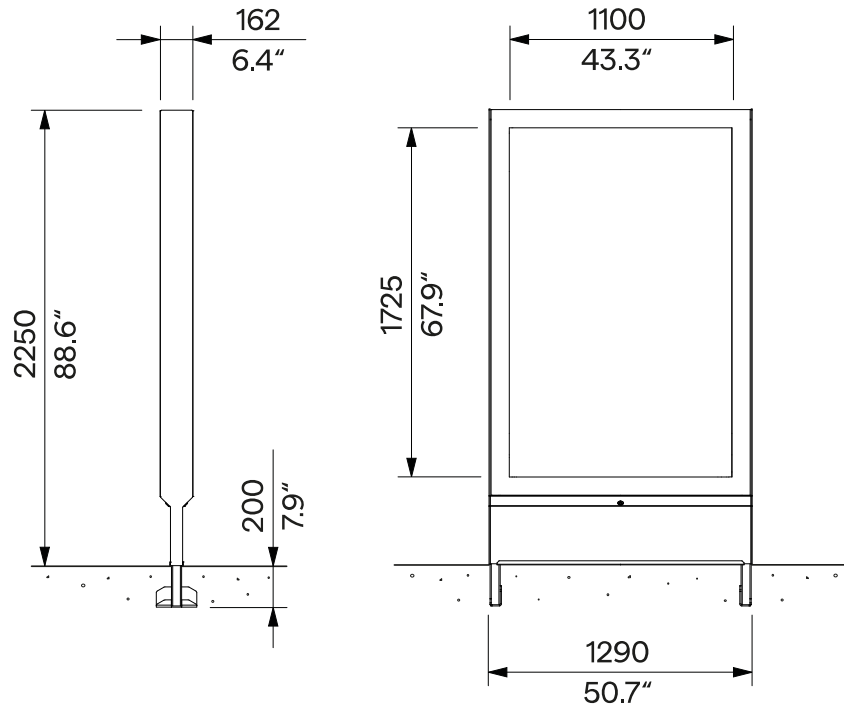
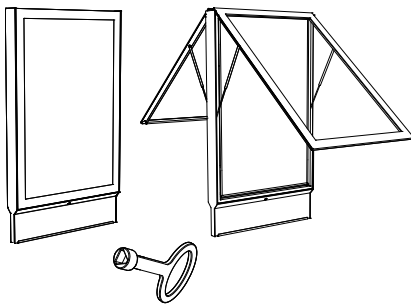

Design	Egoé studio
Character	<p>Illuminated double-sided 'Citylight showcase' for information and advertising posters (1185 x 1750 mm [3' 10.7" x 5' 8.9"]). The visible area is at least 1100 x 1725 mm [3' 7.3" x 5' 7.9"].</p> <p>LED strips are placed around the entire perimeter.</p> <p>For easy handling of posters, the display case is equipped with a mechanical system that moves the upper clamping plate to a position accessible to the user. The poster is fixed with tension clamps.</p> <p>The display case is equipped with a lockable front wall with tempered glass, concealed hinges, gas struts, complete electrical equipment and a ventilation system against moisture concentration.</p>
Materials	<p>The supporting structure is made of steel profiles. The surface treatment of the supporting frame consists of an anticorrosive protective zinc layer.</p> <p>The sheathing consists of powder coated aluminium alloy sheets. The colours in a fine matt texture can be selected according to „Samplers RAL“.</p> <p>All functional parts are made of stainless steel. Stainless steel (A2) fasteners.</p> <p>Tempered ESG safety glass with a thickness of 5 mm [0.197"] and with screen printing around.</p> <p>Diffusing opal polycarbonate plate.</p>
LED Lighting Parameters	<ul style="list-style-type: none"> » Chromaticity 3 000 K (Daylight white color) » Luminous flux 180 LM / W » Power consumption 39 W » Input voltage 230 VA 50 Hz » Nominal voltage 24 VDC » Lifetime up to 50 000 hours » Protection class IP44
Anchoring	<p>Before installation, a 230 V power cable must be connected / CYKY J 3x1.5 - the usual cross-section, or larger depending on the specific situation. The cable is not included.</p> <p>Anchoring to the concrete foundation under the pavement using galvanised steel threaded rods with chemical anchor according to the valid anchorage drawing.</p> <p>All elements of the street furniture must be properly anchored, otherwise there is a risk of the product falling over during careless use, for which the manufacturer is not responsible.</p>
Option	LED lighting parameters (chromaticity, luminous flux, power consumption) can be customised in agreement with the client.
Maintenance	Use the usual non-invasive cleaning methods suitable for street furniture, see the manual „ Inspection and maintenance “.
Weight	189 kg [417 lbs]

Technical Sheet / technisches Arbeitsblatt

The dimensions of the products are informative. We reserve the right to change the specifications without notice. For the most current version of this document please refer to our website.
Die Abmessungen sind informativ. Wir behalten uns das Recht vor, die Spezifikationen ohne vorherige Ankündigung zu ändern. Die gültige Version dieses Dokuments finden Sie auf unserer Website.